

© COPYRIGHT 1975 BY AMP INCORPORATED, HARRISBURG, PA. ALL INTERNATIONAL RIGHTS RESERVED. AMP INCORPORATED PRODUCTS COVERED BY U. S. AND FOREIGN PATENTS AND/OR PATENTS PENDING.

| P | F | ZONE | LTR | DESCRIPTION | DATE | APPROVED |
|---|---|------|-----|---|-------------|----------|
| | | O3 | | REWORKED FROM 100 TO 100 THRU 4-0 BENS 1006 F1013 | 7-2-75 | |
| | | O4 | | ADDED NOTE 1 ECN 2762 | 10-5-78 | AKJ |
| | | O5 | | REV ECN 2837 | 1-19-89 | 30 |
| A | ✓ | A | | REV PER ECN AR 2383 | DK 4-11-89 | |
| B | ✓ | B | | REACTIVATE -21 & -25 REL# 3062 JFG | 8-7-89 | DLG |
| C | ✓ | C | | REV LOC 3, DIST AD-4171 | 11-28-89 | BF |
| D | ✓ | D | | REV PER 0010-1352-93 | JFK 1-20-94 | JFK |
| E | ✓ | E | | EC 0010-1359-93 | T.H. | JFK |

| PART NO. | NO. OF PDS. | B | C | A |
|-----------|-------------|----|-------|-------|
| 87346-1 | 20 | 9 | .900 | .584 |
| 2 | 26 | 12 | 1.200 | 1.284 |
| 3 | 4 | 1 | .100 | .184 |
| 4 | 50 | 24 | 2.400 | 2.484 |
| 5 | 10 | 4 | .400 | .484 |
| 6 | 40 | 19 | 1.900 | 1.984 |
| 7 | 2 | — | — | .084 |
| 8 | 6 | 2 | .200 | .284 |
| 9 | 8 | 3 | .300 | .384 |
| 1-87346-0 | 12 | 5 | .500 | .584 |
| 1 | 14 | 6 | .600 | .684 |
| 1 | 16 | 7 | .700 | .784 |
| 1 | 18 | 8 | .800 | .884 |
| 1 | 22 | 10 | 1.000 | 1.084 |
| 1 | 24 | 11 | 1.100 | 1.184 |
| 1 | 28 | 13 | 1.300 | 1.384 |
| 1 | 30 | 14 | 1.400 | 1.484 |
| 1 | 32 | 15 | 1.500 | 1.584 |
| 1 | 34 | 16 | 1.600 | 1.684 |
| 2-87346-0 | 36 | 17 | 1.700 | 1.784 |
| 2 | 38 | 18 | 1.800 | 1.884 |
| 2 | 42 | 20 | 2.000 | 2.084 |
| 2 | 44 | 21 | 2.100 | 2.184 |
| 2 | 46 | 22 | 2.200 | 2.284 |
| 2 | 48 | 23 | 2.300 | 2.384 |
| 2 | 52 | 25 | 2.500 | 2.584 |
| 2 | 54 | 26 | 2.600 | 2.684 |
| 2 | 56 | 27 | 2.700 | 2.784 |
| 2 | 58 | 28 | 2.800 | 2.884 |
| 3-87346-0 | 60 | 29 | 2.900 | 2.984 |
| 3 | 62 | 30 | 3.000 | 3.084 |
| 3 | 64 | 31 | 3.100 | 3.184 |
| 3 | 66 | 32 | 3.200 | 3.284 |
| 3 | 68 | 33 | 3.300 | 3.384 |
| 3 | 70 | 34 | 3.400 | 3.484 |
| 3 | 72 | 35 | 3.500 | 3.584 |
| 3 | 74 | 36 | 3.600 | 3.684 |
| 3 | 76 | 37 | 3.700 | 3.784 |
| 3 | 78 | 38 | 3.800 | 3.884 |
| 4-87346-0 | 80 | 39 | 3.900 | 3.984 |

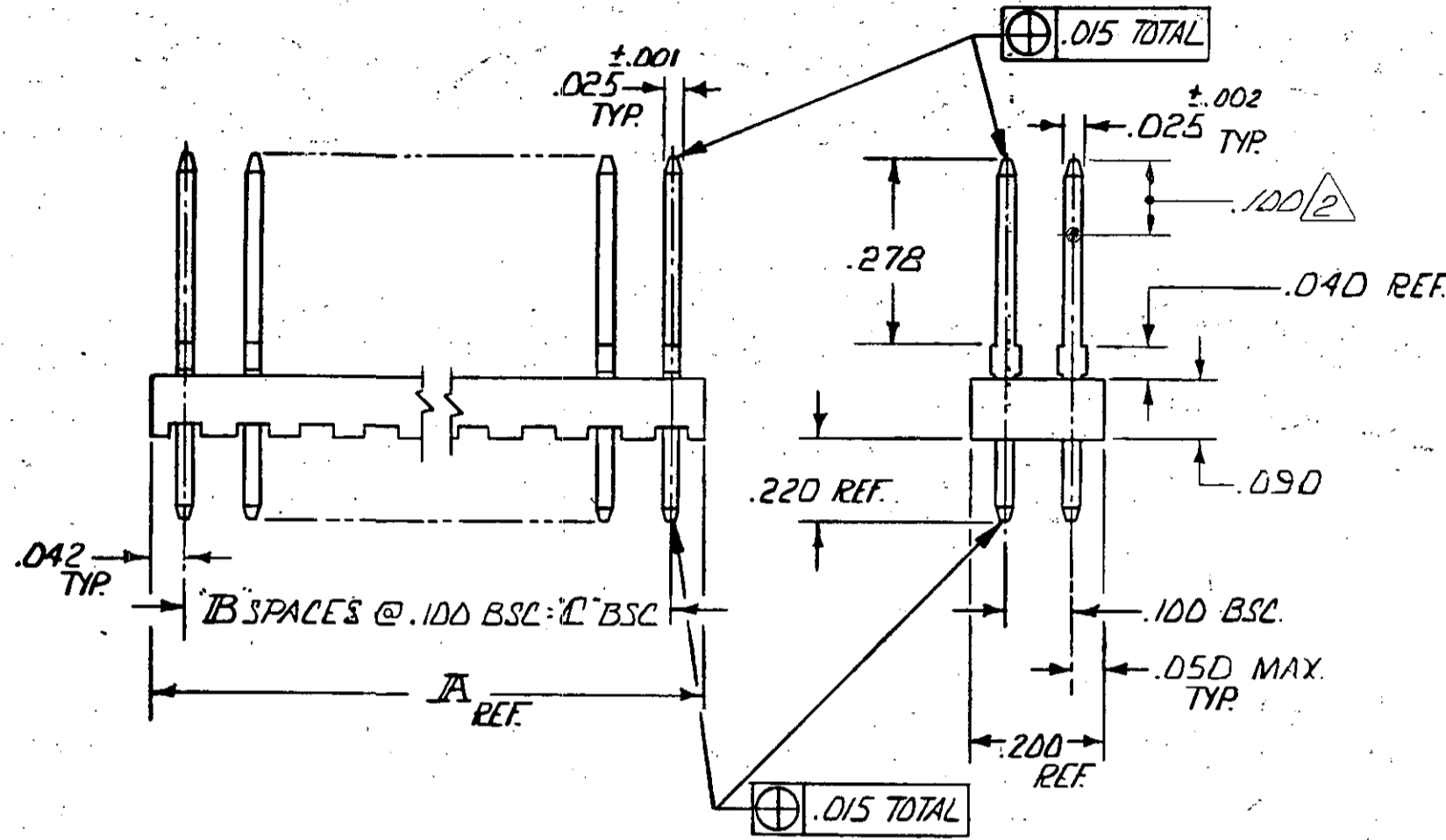

- 1. TRUE POSITION TOLERANCE OF POST TIPS APPLIES WHEN HEADERS ARE HELD FLAT AGAINST PRINTED CIRCUIT BOARD.
- 2. POINT OF MEASUREMENT FOR PLATING THICKNESS.
- 3. OBSOLETE PART NUMBER.

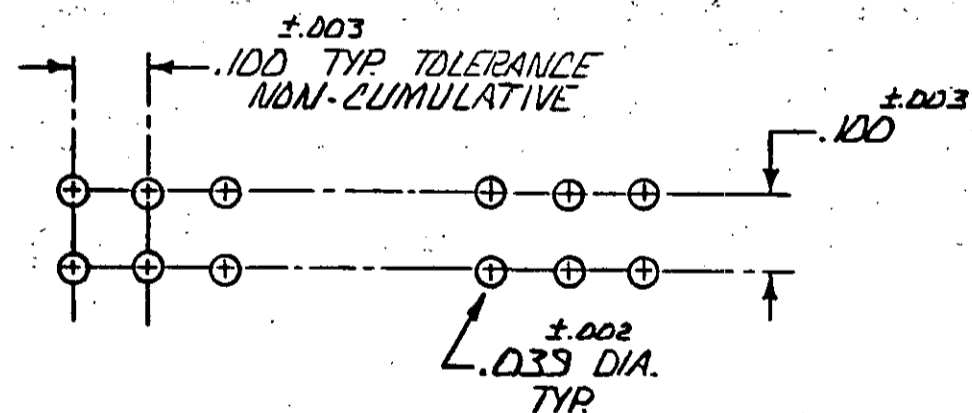

RECOMMENDED HOLE LAYOUT

| | | | | | |
|--|--|--------------------------|--|--|--|
| UNLESS OTHERWISE SPECIFIED DIMENSIONS ARE IN INCHES. TOLERANCES ON: DECIMALS ±.005 ANGLES ± | | CONTRACT NO | | PART NO | |
| MATERIAL HSB. - GLASS FILLED NYLON COLOR: BLACK POST - PHOS. BRONZE | | DR D. Munn 7/10/75 | | AMP INCORPORATED Harrisburg, Pa. | |
| FINISH POST - .000015 GOLD OVER .000050 NICKEL | | CHK B. Wolfe 7-11-75 | | NAME HOUSING ASSEMBLY, MOD II, 100 x 100 GRID, DBL ROW | |
| | | APPD B. Wolfe 7/29/75 | | SIZE CODE IDENT NO DRAWING NO C 00779 87346 | |
| | | DSGN APPD | | SCALE | |
| | | OTHER APPD | | SHEET 1 of 1 | |